

TRAY KIT	TRAY LENGTH	TRAVEL	LENGTH	REAR BRACKET ADJUSTMENT RANGE	LOAD RATING PER TRAY
PART NO.	L	T	A	B	
T1U-100S-14	14.00	14.88	16.00	14.00 TO 20.00	126 LBS
T1U-100S-16	16.00	16.88	18.00	16.00 TO 22.00	122 LBS
T1U-100S-18	18.00	18.88	20.00	16.00 TO 24.00	118 LBS
T1U-100S-20	20.00	20.88	22.00	18.00 TO 26.00	112 LBS
T1U-100S-22	22.00	22.88	24.00	20.00 TO 28.00	107 LBS
T1U-100S-24	24.00	24.88	26.00	22.00 TO 30.00	102 LBS
T1U-100S-26	26.00	26.88	28.00	24.00 TO 32.00	96 LBS
T1U-100S-28	28.00	28.88	30.00	26.00 TO 34.00	90 LBS

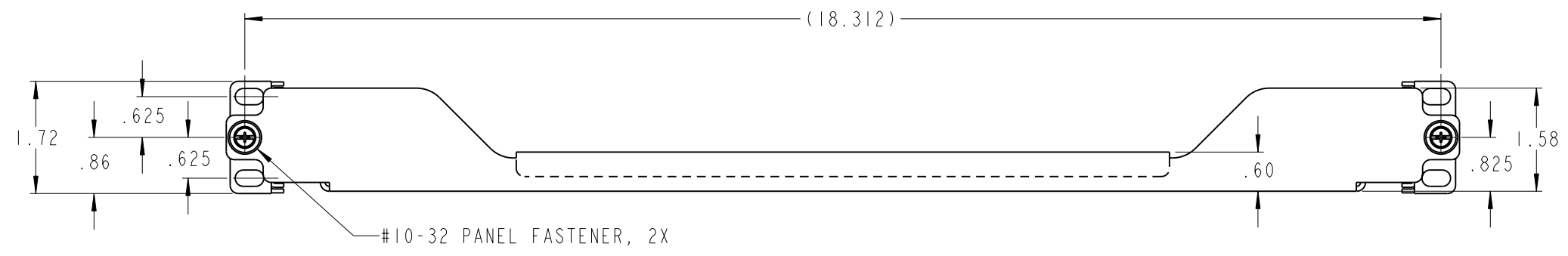
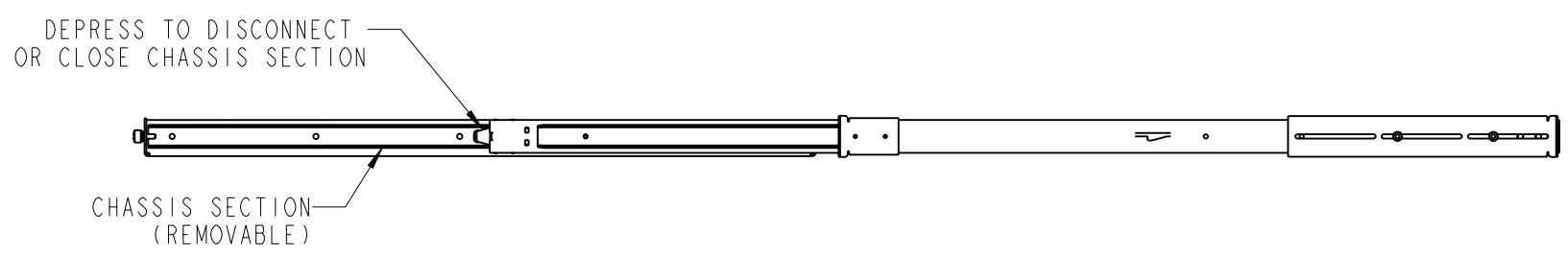
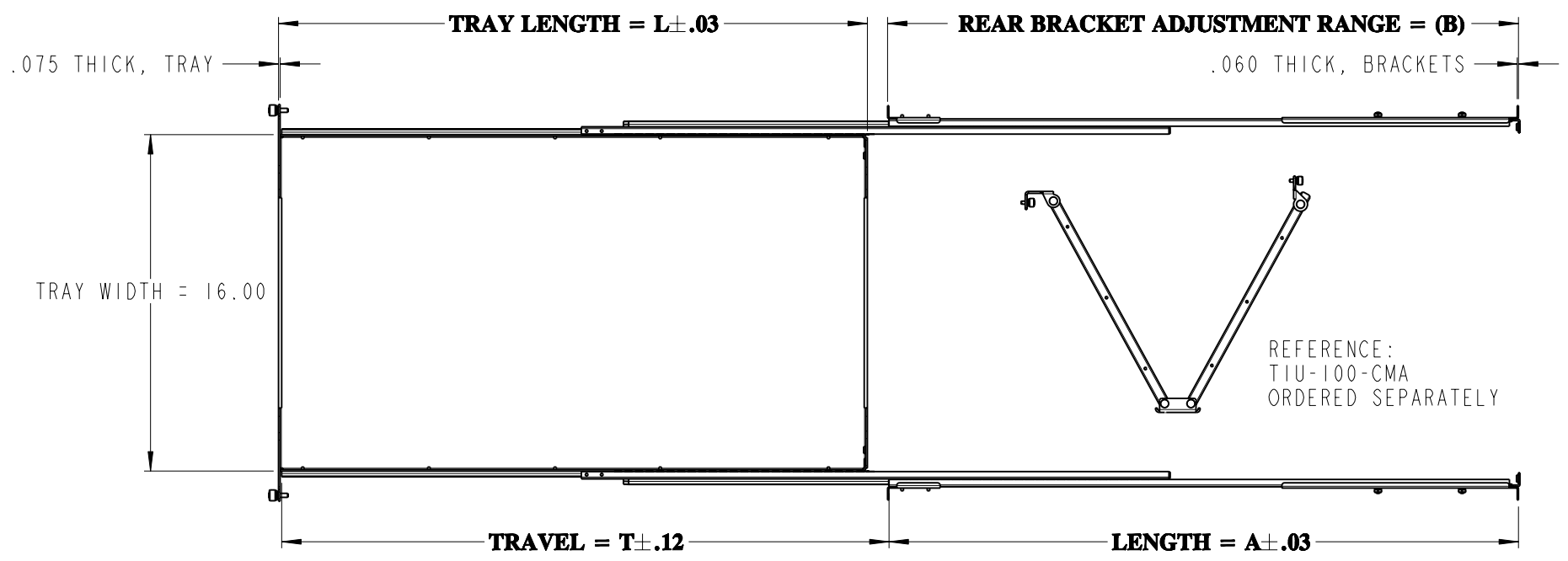

FRONT VIEW

7. TRAY IS SYMMETRICAL AND MAY BE MOUNTED AS A SHELF OR TRAY AS SHOWN ON SHEET 2 OF 2. TO CONVERT, SIMPLY DISCONNECT, FLIP OVER AND RE-INSTALL

6. TRAY KIT INCLUDES:

- 1 EA. SLIDES ASSY AND TRAY RIVETED
- 1 EA. HARDWARE KIT:
 - 12 EA. CLIP NUTS #10-32
 - 10 EA. SCREWS PHPH #10-32 X 1/2" SS

- 5. SLIDE LOCKS IN FULL OPEN POSITION AND IS PROVIDED WITH QUICK DISCONNECT OF CHASSIS SECTION.
- 4. SLIDE BALL RETAINER: C1010 CRS. BRIDGED FOR TRU-TRACKING.
- 3. SLIDE LUBRICATION: EXTREME PRESSURE HI-LOW TEMPERATURE POLYMER GREASE.
- 2. FINISH: SLIDE CHANNELS AND BRACKETS ARE COMMERCIAL ZINC PLATE. TRAY IS POLYURETHANE BLACK POWDER COAT.
- 1. MATERIAL: SLIDE CHANNELS, BRACKETS AND TRAY ARE COLD ROLLED STEEL.

JONATHAN
Engineered Solutions

Irvine Technology Center
410 Exchange, Suite 200
Irvine, CA 92602
Tel. (714) 665-4400
Fax: (714) 368-7002
Website: www.jonathanengr.com
Engineer - Production - Integration/ Subassembly - Logistics
United States - Mexico - China - Taiwan

<i>TOLERANCES UNLESS OTHERWISE NOTED</i>				PART NUMBER: T1U-100S		DESCRIPTION: STEEL T1U-100S LOAD RATING : 90-126 LBS.	
.XX	.XXX	ANGLES	HOLES	DATE: 01/21/14			
± .03	± .010	± 2°	± .005				
SHEET 1 OF 2				COPYRIGHT © 2012 JONATHAN ENGINEERED SOLUTIONS			

1

2

3

4

5

A

A

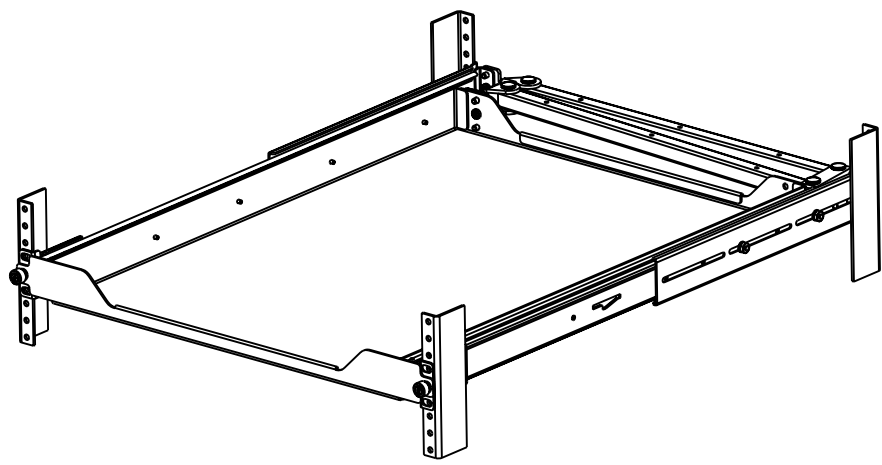

TRAY MOUNTING

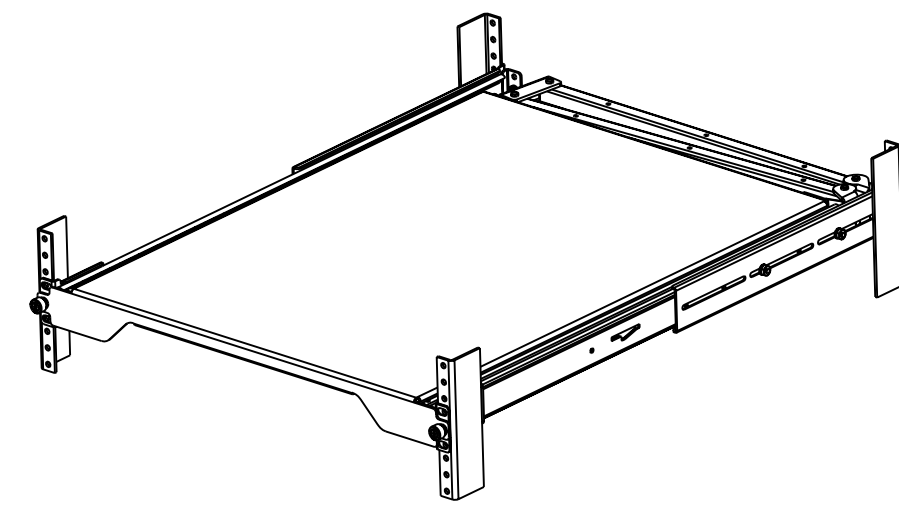

SHELF MOUNTING

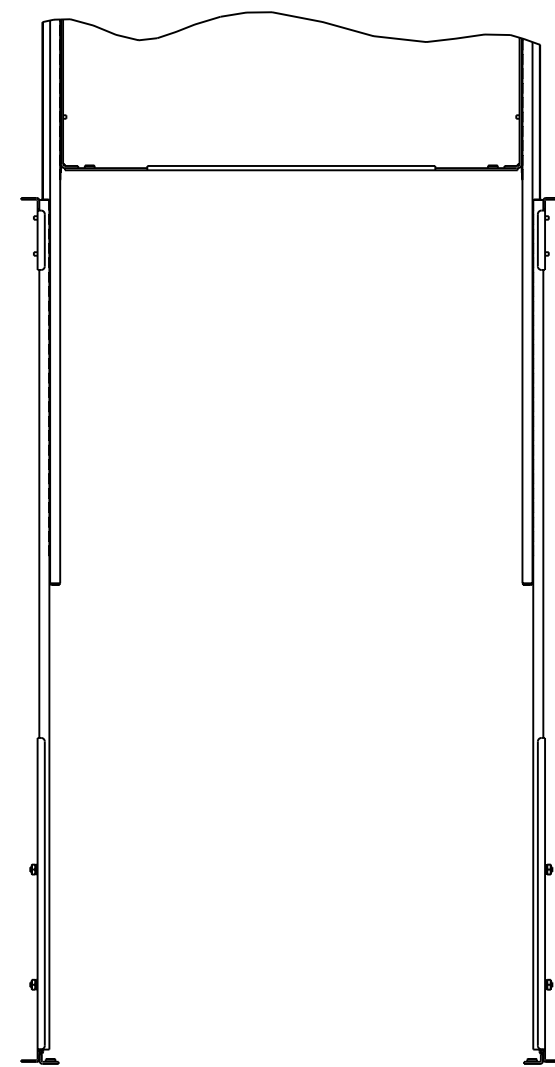

OPEN POSITION SHOWN

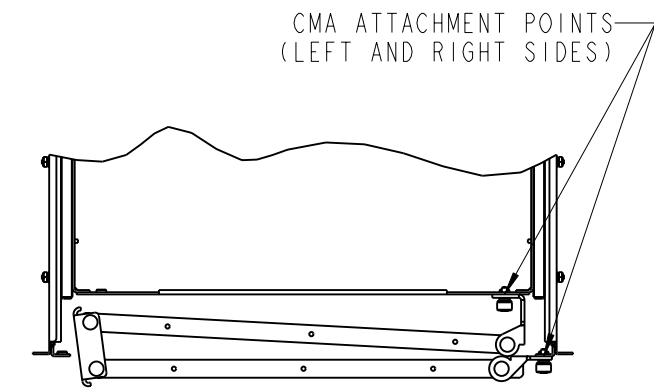

CLOSED POSITION SHOWN

8. ACCESSORIES: ORDER SEPARATELY

- TIU-100-CMA IU CABLE ARM ASSEMBLY - CRS, ZINC PLATE
- TK-STP-4-K STRAP WITH METAL CAM BUCKLE KIT
2 EA. STRAP WITH BUCKLE 4 FEET LONG
- TK-STP-5-K STRAP WITH METAL CAM BUCKLE KIT
2 EA. STRAP WITH BUCKLE 5 FEET LONG
- TK-MAT-1212 ANTI SLIP MAT 12" X 12"
- TK-MAT-1218 ANTI SLIP MAT 12" X 18"
- TK-HLT STRAP TRAY KIT
4 EA. .75 X 14.00 STRAP
- TK-HLC HOOK AND LOOP CMA KIT
4 EA. .50 X 8.00 HOOK AND LOOP STRAP



Irvine Technology Center
 410 Exchange, Suite 200
 Irvine, CA 92602
 Tel. (714) 665-4400
 Fax: (714) 368-7002
 Website: www.jonathanengr.com
 Engineer - Production - Integration/ Subassembly - Logistics
 United States - Mexico - China - Taiwan

TOLERANCES UNLESS OTHERWISE NOTED				PART NUMBER :		DESCRIPTION :
				T1U-100S		
.XX	.XXX	ANGLES	HOLES	DATE :		COPYRIGHT © 2012 JONATHAN ENGINEERED SOLUTIONS
± .03	± .010	± 2°	± .005	01/21/14		
SHEET 2 OF 2						

1

2

3

4

5

D

D

E

E