

	1	2		3	4	5
	TRAY KIT	TRAY LENGTH	TRAVEL	LENGTH	REAR BRACKET ADJUSTMENT RANGE	LOAD RATING PER TRAY - LBS
	PART NO.	L	T	A	B	
A	T2U-200S-14	14.00	14.00	16.00	18.00 - 20.00	254
	T2U-200S-16	16.00	16.00	18.00	18.00 - 22.00	234
	T2U-200S-18	18.00	18.00	20.00	18.00 - 24.00	206
	T2U-200S-20	20.00	20.00	22.00	18.00 - 26.00	189
	T2U-200S-22	22.00	22.00	24.00	20.00 - 28.00	174
	T2U-200S-24	24.00	24.00	26.00	22.00 - 30.00	161
	T2U-200S-26	26.00	26.00	28.00	24.00 - 32.00	152
	T2U-200S-28	28.00	28.00	30.00	26.00 - 34.00	144

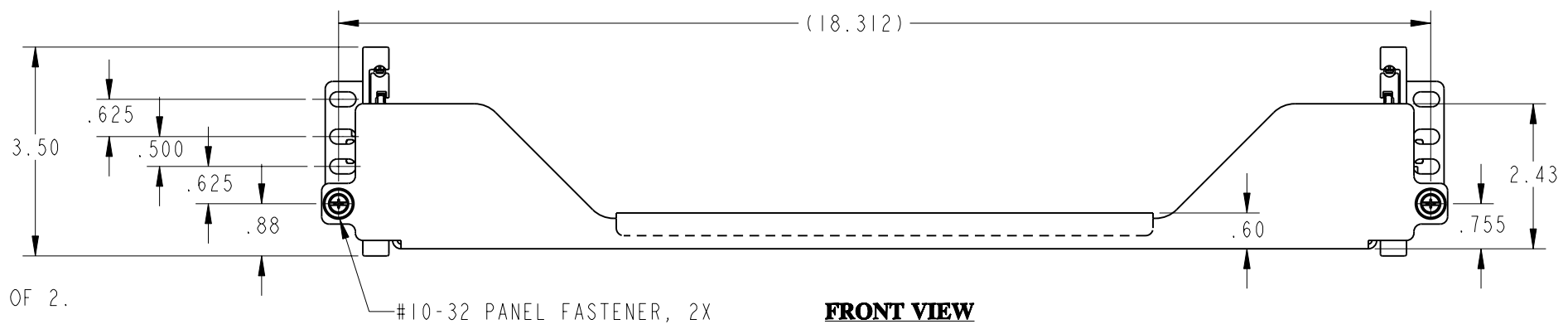
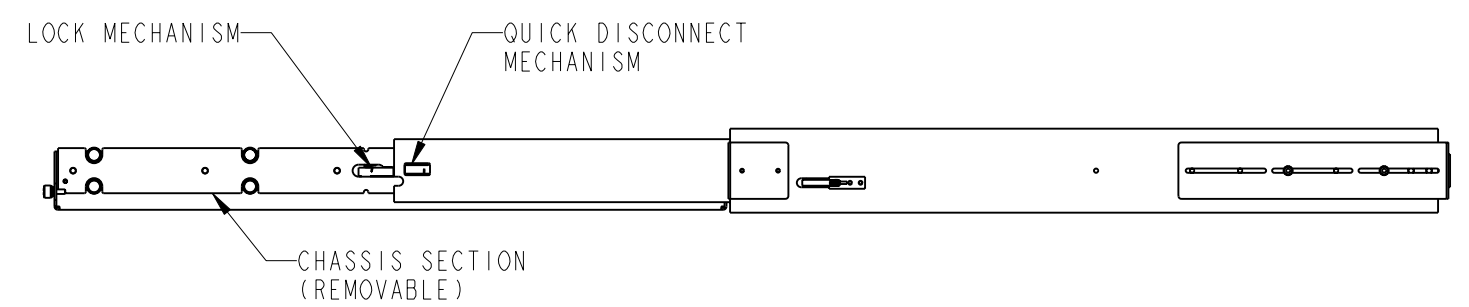
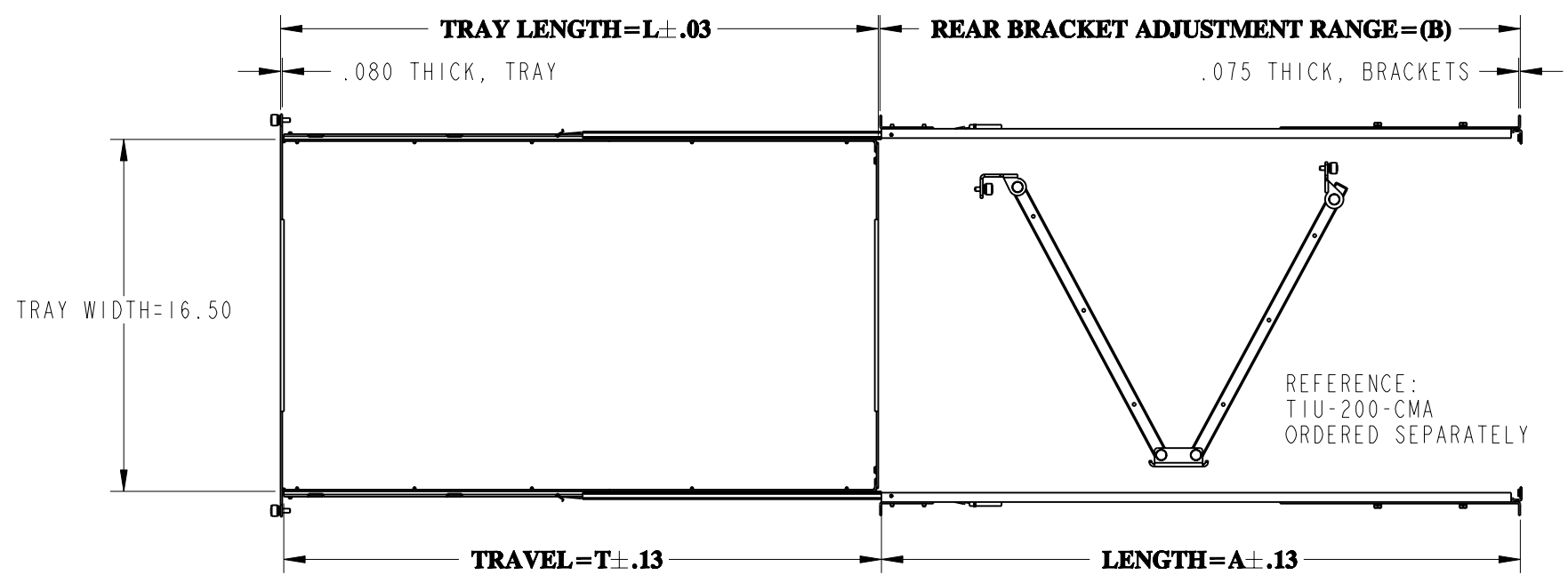

5. TRAY IS SYMMETRICAL AND MAY BE MOUNTED AS A SHELF OR TRAY AS SHOWN ON SHEET 2 OF 2. TO CONVERT, SIMPLY DISCONNECT, FLIP OVER AND RE-INSTALL.

4. TRAY KIT INCLUDES :
 1 EA. SLIDES ASSEMBLY AND TRAY RIVETED
 1 EA. HARDWARE KIT:
 12 EA. CLIP NUTS #10-32
 10 EA. SCREWS PHPH #10-32 X 1/2" SS

3. SLIDE LOCKS IN FULL OPEN POSITION AND IS PROVIDED WITH QUICK DISCONNECT OF CHASSIS SECTION.

2. FINISH: SLIDE CHANNELS AND ALUMINUM COMPONENTS ARE ANODIZED PER MIL-A-8625, TYPE II, CLASS I. STAINLESS STEEL COMPONENTS ARE PASSIVATED PER SAE-AMS-2700 TRAY IS POLYURETHANE BLACK POWDER COAT.

1. MATERIAL: SLIDE CHANNELS AND TRAY ARE FABRICATED FROM HIGH STRENGTH ALUMINUM ALLOYS. BRACKETS ARE STAINLESS STEEL. COMPONENT PARTS AND FASTENERS ARE HIGH STRENGTH ALUMINUM ALLOYS AND STAINLESS STEEL.

JONATHAN
Engineered Solutions

Irvine Technology Center
 410 Exchange, Suite 200
 Irvine, CA 92602
 Tel. (714) 665-4400
 Fax: (714) 368-7002
 Website: www.jonathanengr.com
 Engineer - Production - Integration/ Subassembly - Logistics
 United States - Mexico - China - Taiwan

<i>TOLERANCES UNLESS OTHERWISE NOTED</i>				PART NUMBER : T2U-200S		DESCRIPTION : ALUMINUM T2U-200S	
.XX	.XXX	ANGLES	HOLES	DATE : 01/22/14		LOAD RATING : 144-254 LBS.	
± .03	± .010	± 2°	± .005	SHEET 1 OF 2		COPYRIGHT © 2012 JONATHAN ENGINEERED SOLUTIONS	

1

2

3

4

5

A

A

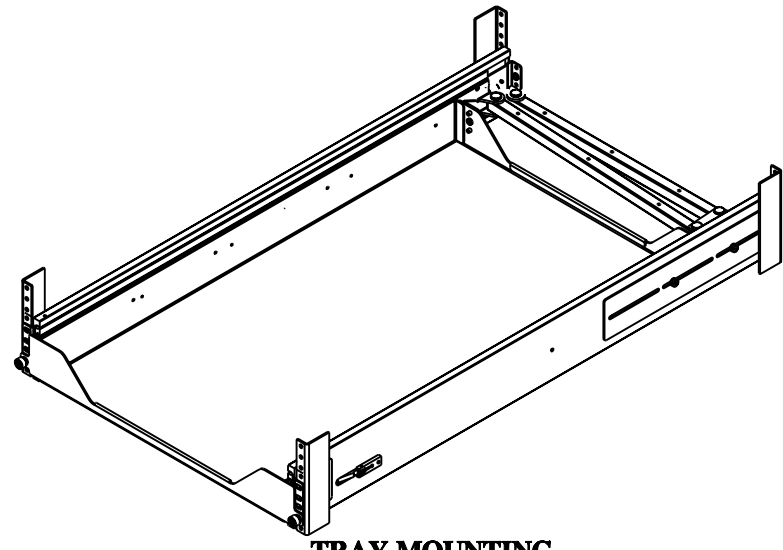

TRAY MOUNTING

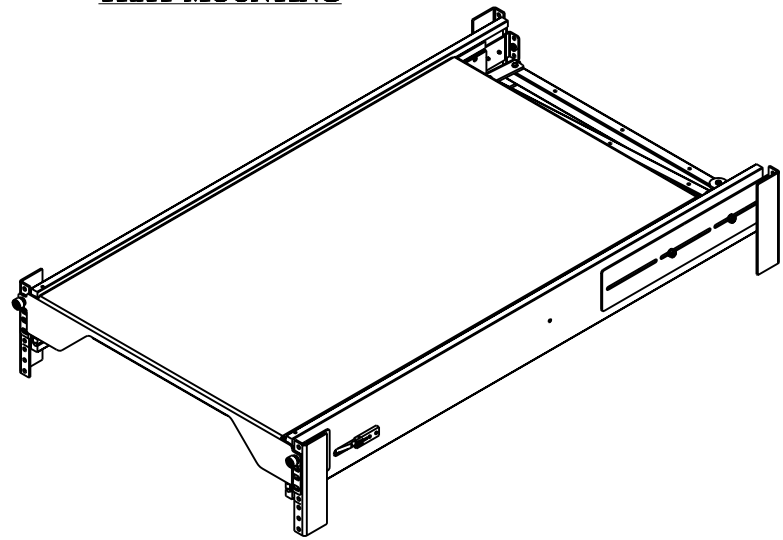

SHELF MOUNTING

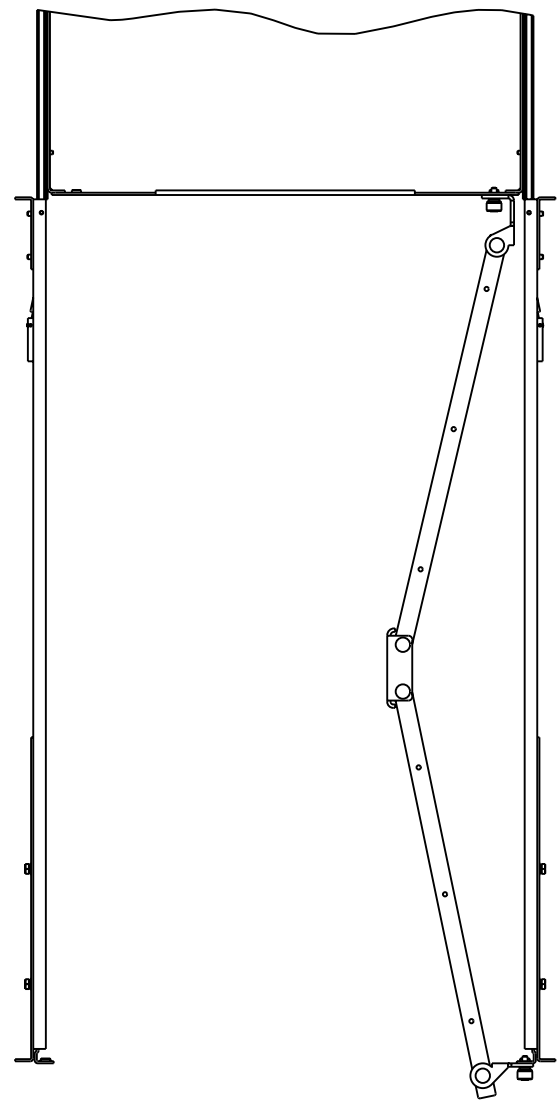

OPEN POSITION SHOWN

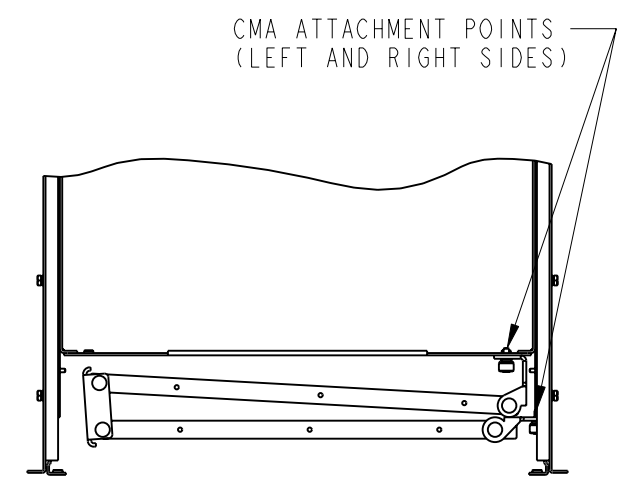

CLOSED POSITION SHOWN

6. ACCESSORIES: ORDERED SEPARATELY

- TIU-200-CMA IU CABLE ARM ASSEMBLY - STAINLESS STEEL
- TK-STP-4-K STRAP WITH METAL CAM BUCKLE KIT
2 EA. STRAP WITH BUCKLE 4 FEET LONG.
- TK-STP-5-K STRAP WITH METAL CAM BUCKLE KIT
2 EA. STRAP WITH BUCKLE 5 FEET LONG.
- TK-MAT-1212 ANTI SLIP MAT 12" X 12"
- TK-MAT-1218 ANTI SLIP MAT 12" X 18"
- TK-HLT STRAP TRAY KIT
4 EA. .75 X 14.00 STRAP
- TK-HLC HOOK AND LOOP CMA KIT
4 EA. .50 X 8.00 HOOK AND LOOP STRAP



Irvine Technology Center
410 Exchange, Suite 200
Irvine, CA 92602
Tel. (714) 665-4400
Fax: (714) 368-7002
Website: www.jonathanengr.com
Engineer - Production - Integration/ Subassembly - Logistics
United States - Mexico - China - Taiwan

TOLERANCES UNLESS OTHERWISE NOTED				PART NUMBER :		DESCRIPTION :
				T2U-200S		
.XX	.XXX	ANGLES	HOLES	DATE :		COPYRIGHT © 2012 JONATHAN ENGINEERED SOLUTIONS
± .03	± .010	± 2°	± .005	01/22/14		
SHEET 2 OF 2						

1

2

3

4

5

D

D

E

E