

TRAY KIT	TRAY LENGTH	TRAVEL	LENGTH	REAR BRACKET ADJUSTMENT RANGE	LOAD RATING PER TRAY
PART NO.	L	T	A	B	
T1U-155-14	14.00	14.88	14.00	14.00 TO 20.00	126 LBS
T1U-155-16	16.00	16.88	16.00	16.00 TO 22.00	122 LBS
T1U-155-18	18.00	18.88	18.00	16.00 TO 24.00	118 LBS
T1U-155-20	20.00	20.88	20.00	18.00 TO 26.00	112 LBS
T1U-155-22	22.00	22.88	22.00	20.00 TO 28.00	107 LBS
T1U-155-24	24.00	24.88	24.00	22.00 TO 30.00	102 LBS
T1U-155-26	26.00	26.88	26.00	24.00 TO 32.00	96 LBS
T1U-155-28	28.00	28.88	28.00	26.00 TO 34.00	90 LBS

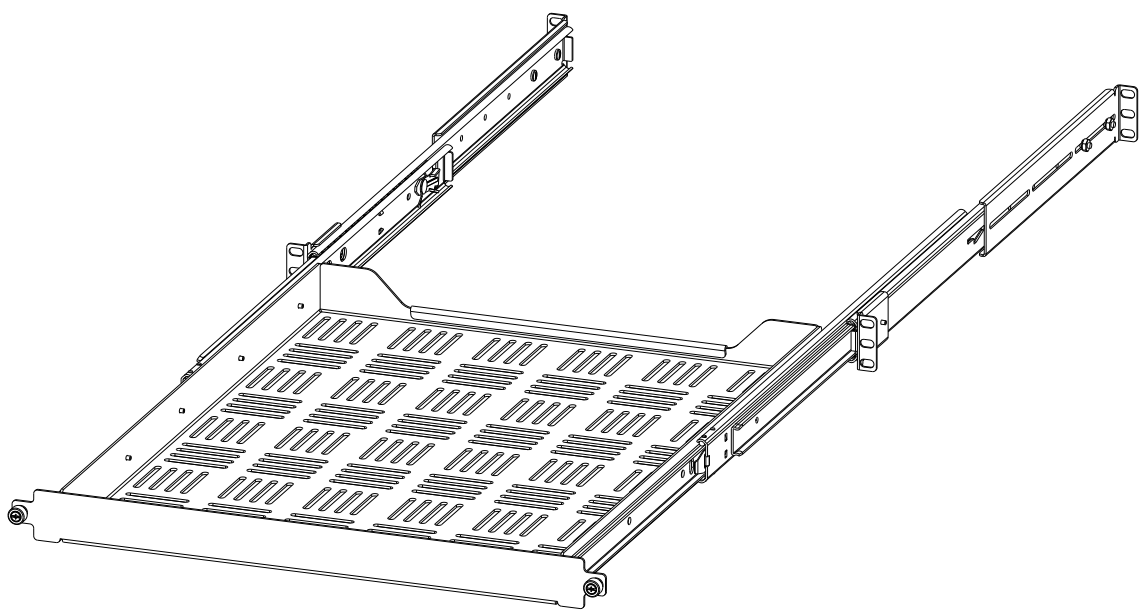

ISO VIEW

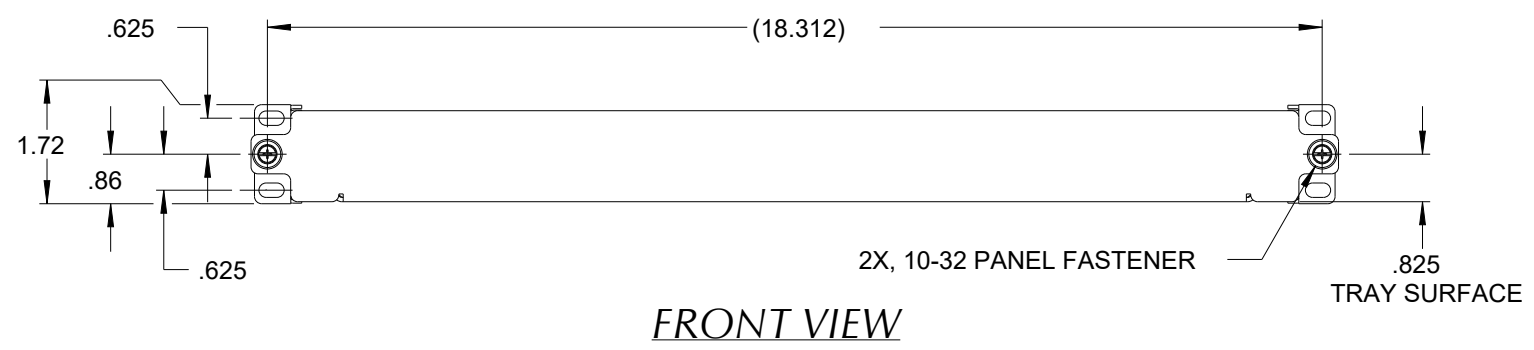
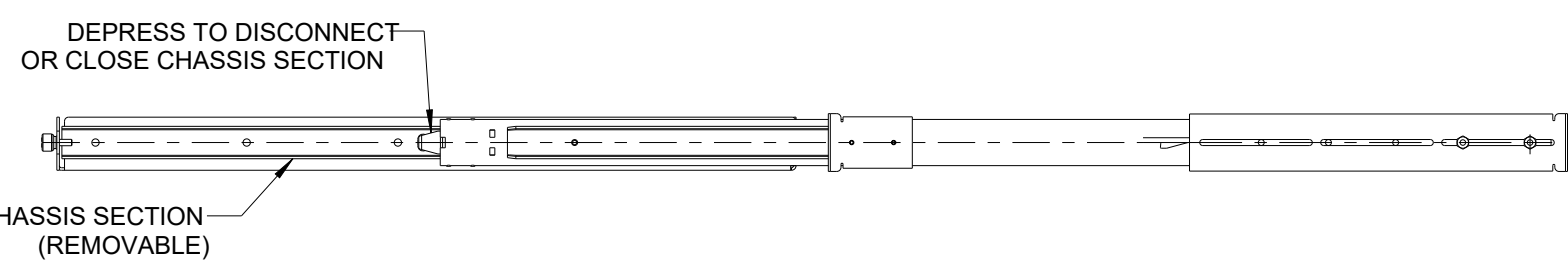
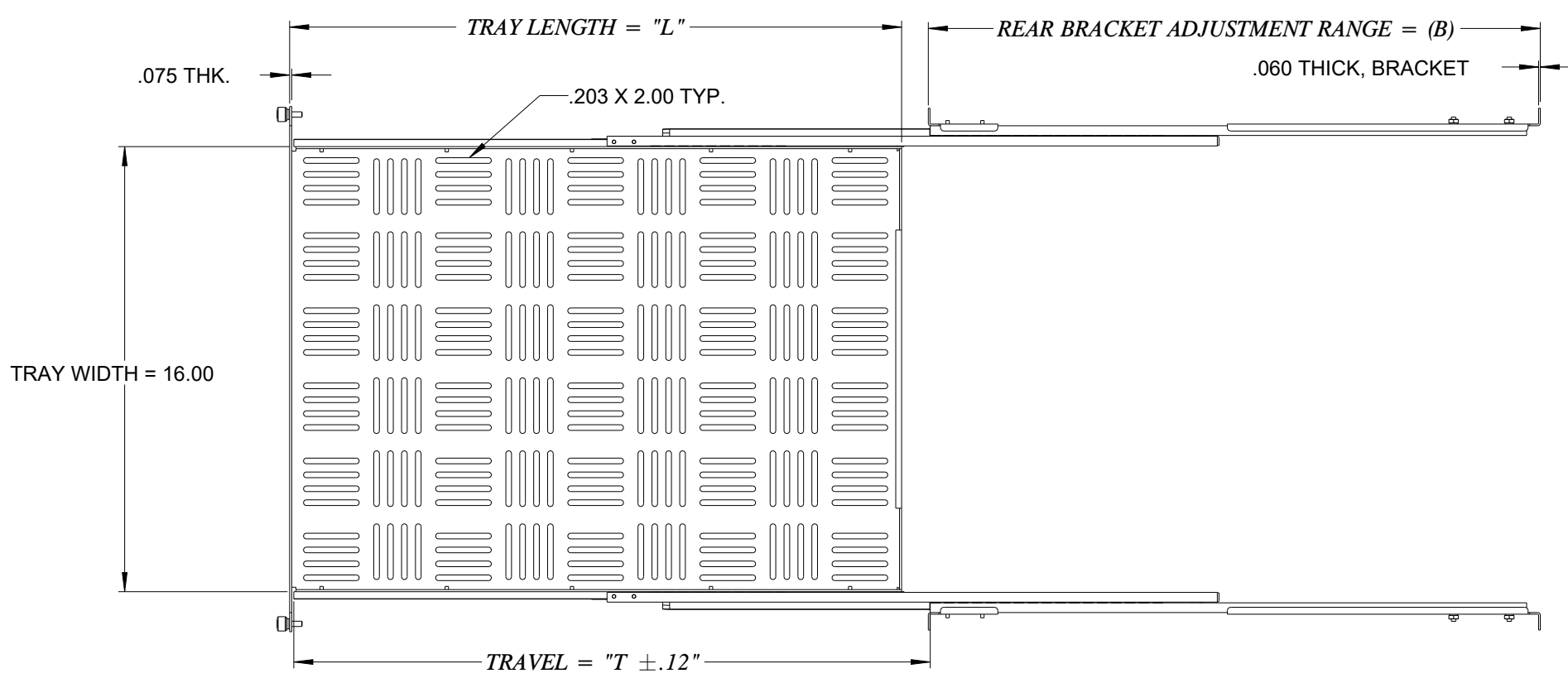

FRONT VIEW

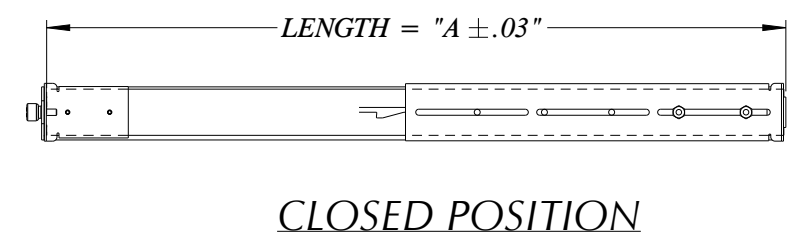

CLOSED POSITION

- MATERIAL: SLIDE CHANNELS, BRACKETS AND TRAY ARE COLD ROLLED STEEL.
- FINISH: SLIDE CHANNELS AND BRACKETS ARE COMMERCIAL ZINC PLATE. TRAY IS POLYURETHANE BLACK POWDER COAT.
- SLIDE LUBRICATION: EXTREME PRESSURE HI-LOW TEMPERATURE POLYMER GREASE.
- SLIDE LOCKS IN FULL OPEN POSITION AND IS PROVIDED WITH QUICK DISCONNECT OF CHASSIS SECTION.
- TRAY KIT INCLUDES:  
1 EA. SLIDES ASSY AND TRAY RIVETED  
1 EA. HARDWARE KIT:  
4 EA. BAR NUT, #10-32 (JES P/N SPO-623)  
10 EA. SCREW, TRUSS HEAD PH #10-32 X 1/2"
- TRAY IS SYMMETRICAL AND MAY BE MOUNTED AS A SHELF OR TRAY AS SHOWN ON SHEET 2 OF 2. TO CONVERT, SIMPLY DISCONNECT, FLIP OVER AND RE-INSTALL

**JONATHAN**  
Engineered Solutions

Irvine Technology Center  
250 Commerce, Suite 100  
Irvine, CA 92602  
Tel. (714) 665-4400  
Fax: (714) 368-7002  
Website: www.jonathanengr.com  
Engineer - Production - Integration/ Subassembly - Logistics  
United States - Mexico - China - Taiwan

TOLERANCES UNLESS OTHERWISE NOTED				PART NUMBER : <b>T1U-155</b>		DESCRIPTION : <b>MATERIAL SERIES LOAD RATING :</b>
.XX	.XXX	ANGLES	HOLES	DATE : 07/24/19		
± .03	± .010	± 2°	± .005			
SHEET 1 OF 2				COPYRIGHT © 2012 JONATHAN ENGINEERED SOLUTIONS		

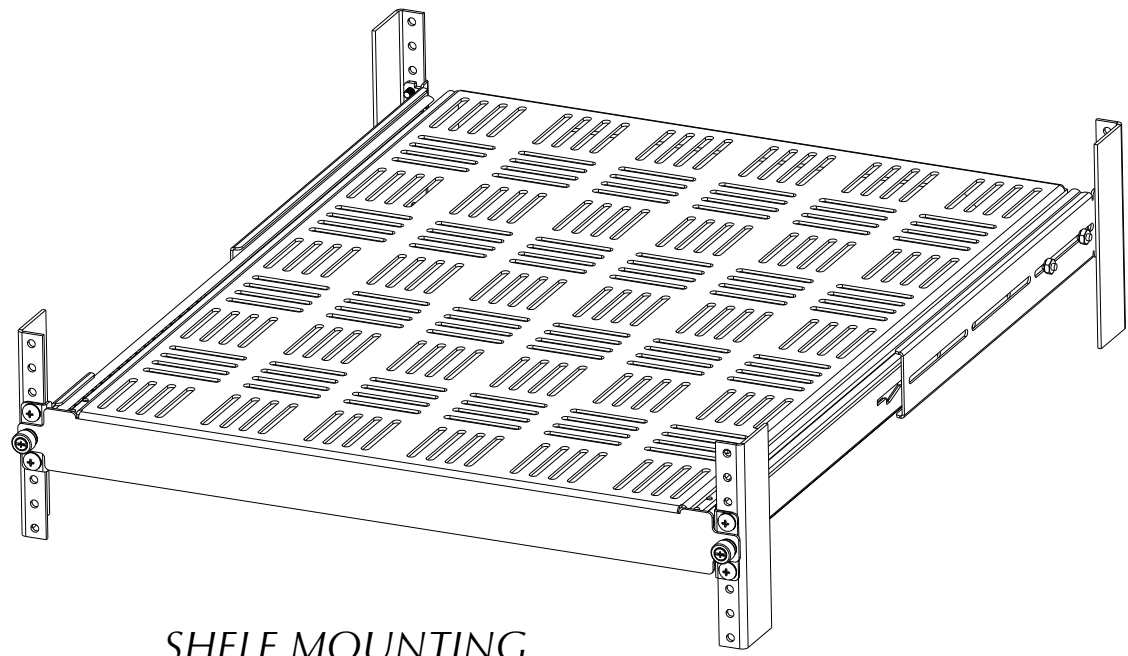

*SHELF MOUNTING*

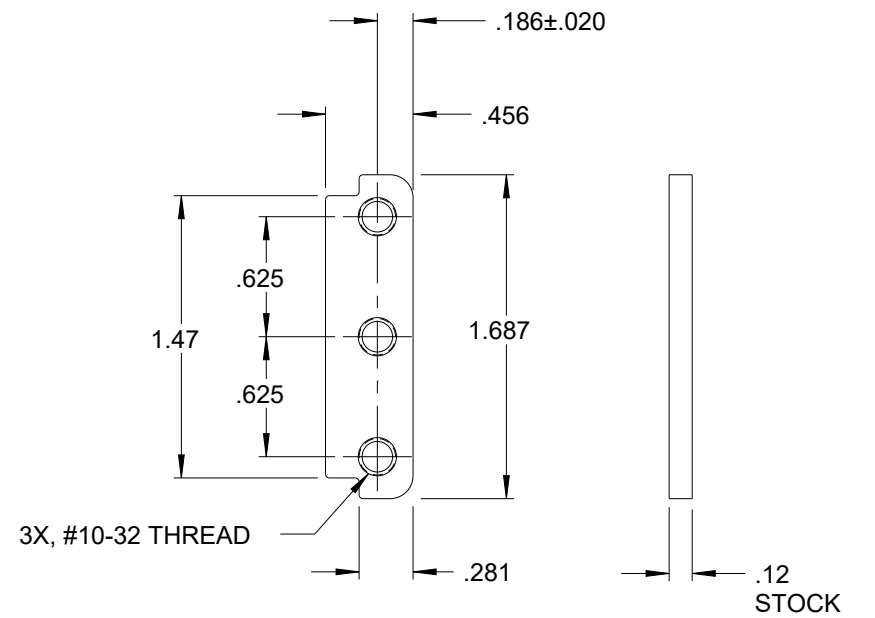
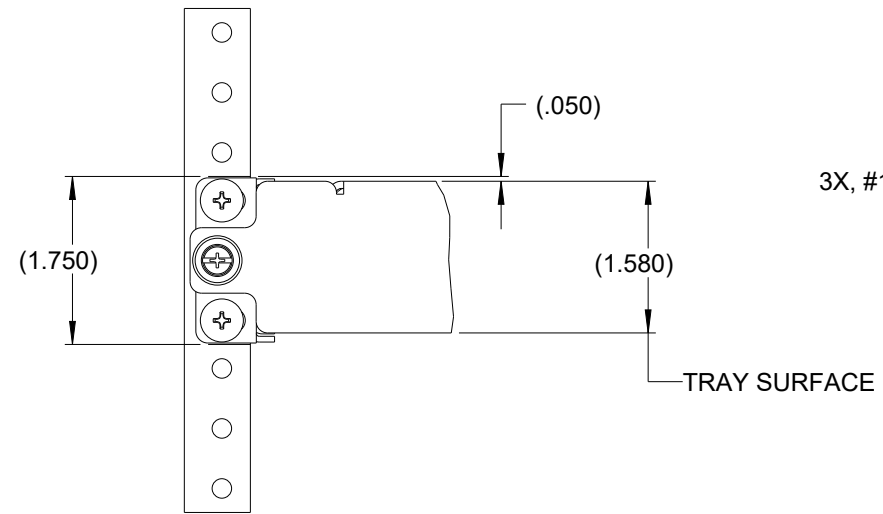

*BAR NUT PART NO.: SPO-623*

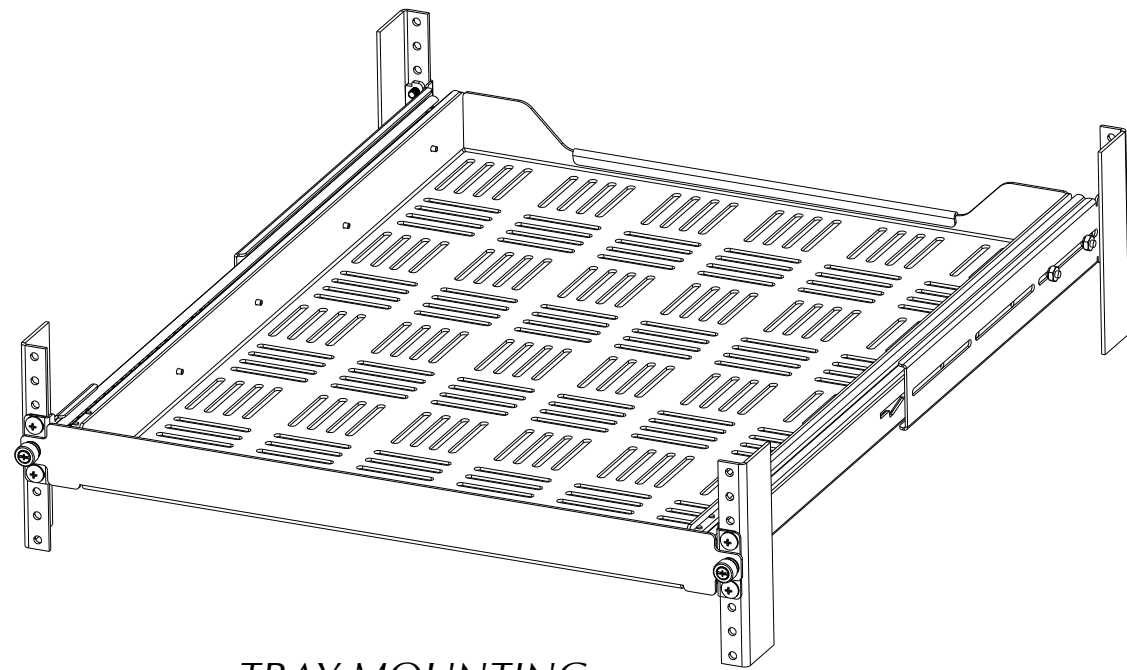

*TRAY MOUNTING*

- ACCESSORIES (SOLD SEPARATELY)

TK-STP-4 STRAP WITH METAL CAM BUCKLE KIT  
(2 EA. STRAP WITH BUCKLE, 4 FEET LONG)

TK-STP-5 STRAP WITH METAL CAM BUCKLE KIT  
(2 EA. STRAP WITH BUCKLE, 5 FEET LONG)

TK-MAT-1212 ANTI-SLIP MAT 12" X 12"  
TK-MAT-1218 ANTI-SLIP MAT 12" X 18"

TK-HLT STRAP TRAY KIT  
(4 EA. .75 X 14.00 HOOK AND LOOP STRAP)



Irvine Technology Center  
250 Commerce, Suite 100  
Irvine, CA 92602  
Tel. (714) 665-4400  
Fax: (714) 368-7002  
Website: www.jonathanengr.com  
Engineer - Production - Integration/ Subassembly - Logistics  
United States - Mexico - China - Taiwan

TOLERANCES UNLESS OTHERWISE NOTED				PART NUMBER :		DESCRIPTION :
				<b>T1U-155</b>		
.XX	.XXX	ANGLES	HOLES	DATE :		
± .03	± .010	± 2°	± .005	07/24/19		
SHEET 2 OF 2				COPYRIGHT © 2012 JONATHAN ENGINEERED SOLUTIONS		