

1. MATERIAL: CHANNELS, SPRING HOUSING AND GUIDE BLOCK: HIGH STRENGTH ALUMINUM ALLOY, TENSILE STRENGTH OF 35,000 PSI PER ASTM B221.  
 HANDLES: ABS BLACK PLASTIC OR NYLON 6/6 NATURAL PLASTIC OR VINYL COATED STAINLESS WIRE.  
 CARRIER: ALUMINUM CHANNEL AND STAINLESS STEEL ANGLE BRACKETS.  
 COMPONENTS AND HARDWARE: STAINLESS STEEL, HIGH STRENGTH ALUMINUM ALLOY OR TEFLON.

2. FINISHES: ALUMINUM - ANODIZED.

3. PULL HANDLE IN DIRECTION SHOWN TO MOVE CARRIER.  
 RELEASE HANDLE TO ALLOW THE CARRIER TO RETURN TO THE RETRACTED POSITION.

**ORDERING INFORMATION**

**EXTR-1000-1-12-H**

EXTRACTOR GLIDE MODEL → HOLES ON BRACKET (BLANK IF NONE)  
 HANDLE STYLE (OPTIONS 1 THRU 4) → SIZE/FEATURES (SEE CHART)

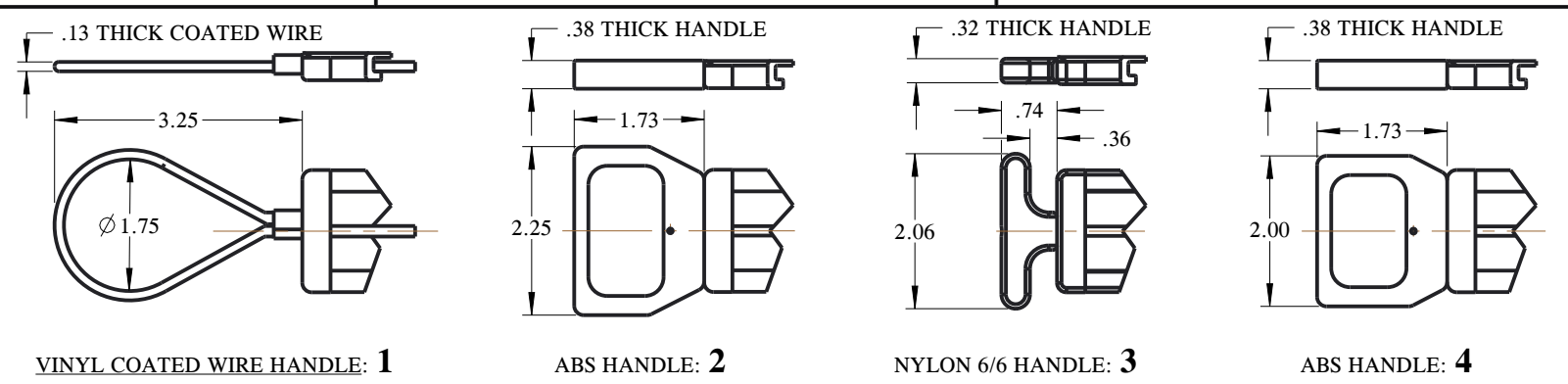

**HANDLE OPTIONS**

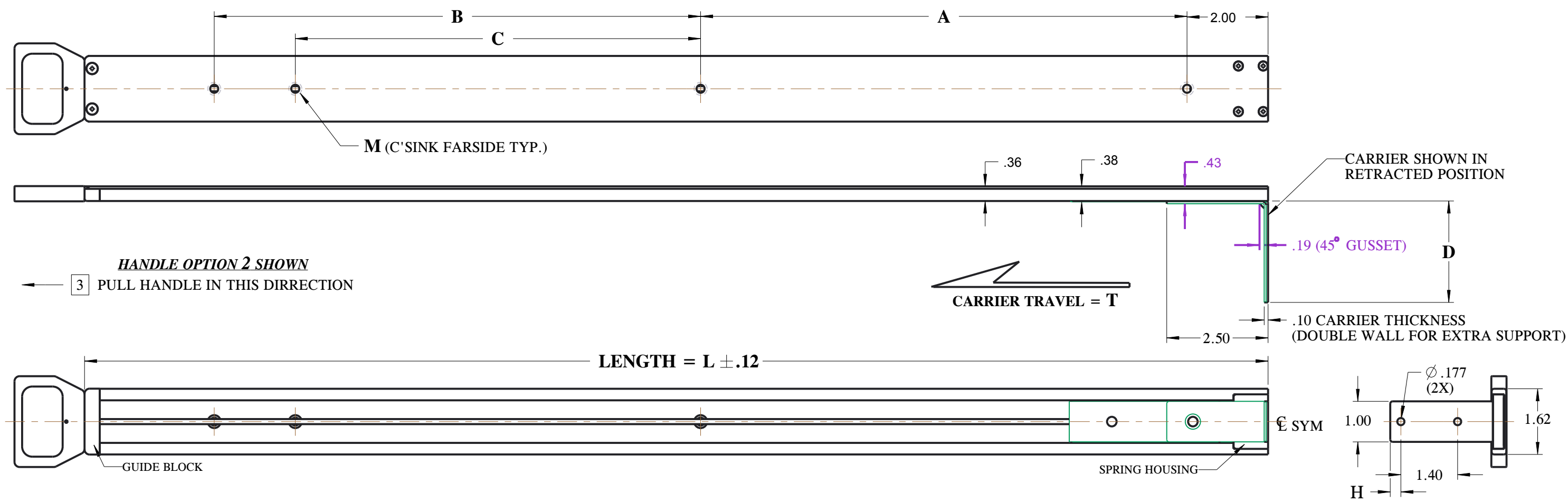

PART NUMBER	LENGTH L	TRAVEL T	MOUNTING HOLES				CARRIER	
			A	B	C	M	D	H
EXTR-1000-2-11	33.20	19.50	14.600	14.600	-	Ø .255 THRU - 100° C'SK X Ø .385	2.50	-
EXTR-1000-2-12	31.20	17.50	13.600	13.600	-	Ø .255 THRU - 100° C'SK X Ø .385	2.50	-
EXTR-1000-2-13	29.20	15.50	12.000	12.000	-	Ø .255 THRU - 100° C'SK X Ø .385	2.50	-
EXTR-1000-2-14	28.20	17.50	12.100	12.100	-	Ø .255 THRU - 100° C'SK X Ø .385	2.50	-
EXTR-1000-2-15	28.20	17.50	12.100	12.100	-	Ø .255 THRU - 100° C'SK X Ø .385	1.50	-
EXTR-1000-2-16	31.20	17.50	13.600	13.600	-	Ø .255 THRU - 100° C'SK X Ø .385	1.50	-
EXTR-1000-2-17	31.20	15.50	13.600	13.600	-	Ø .255 THRU - 100° C'SK X Ø .385	1.50	-
EXTR-1000-2-18	30.00	17.50	14.000	13.500	-	Ø .144 THRU - 100° C'SK X Ø .280	2.50	-
EXTR-1000-2-19	16.75	11.43	6.375	6.375	-	Ø .255 THRU - 100° C'SK X Ø .385	2.50	-
EXTR-1000-2-20	29.30	15.50	12.750	12.750	-	Ø .255 THRU - 100° C'SK X Ø .385	1.50	-
EXTR-1000-2-21	30.00	17.50	14.000	13.500	12.500	Ø .144 THRU - 100° C'SK X Ø .280	2.50	-
EXTR-1000-2-22	21.00	15.05	14.000	4.375	-	Ø .144 THRU - 100° C'SK X Ø .280	2.50	.26



Irvine Technology Center  
 410 Exchange, Suite 200  
 Irvine, CA 92602  
 Tel. (714) 665-4400  
 Fax: (714) 368-7002  
 Website: www.jonathanengr.com  
 Engineer - Production - Integration/ Subassembly - Logistics  
 United States - Mexico - China - Taiwan

TOLERANCES UNLESS OTHERWISE NOTED				PART NUMBER:	DESCRIPTION:	
				<b>EXTR-1000</b>		
.XX	.XXX	ANGLES	HOLES	DATE:		
± .03	± .010	± 1°	± .005	04/15/17	<b>PULL EXTRACTOR</b>	
SHEET 1 OF 1				COPYRIGHT © 2012 JONATHAN ENGINEERED SOLUTIONS		